

Z2D10-12GN

Operating Voltage = 12 VDC
 No Load Current = 1 Amp Max.
 3000 RPM
 Rated Load Current = 2 Amps
 2800 RPM

Z2D10-24GN

Operating Voltage = 24VDC
 No Load Current = 0.5 Amps Max.
 3000 RPM
 Rated Load Current = 0.9 Amps
 2800 RPM

Direction of rotation-Reversible

Change connection polarity to change direction
 Combined Weight ~ = 1.1kg
 Combined Length = 116 mm + shaft

Precision DC PM Motor - Z2D10-12GN & Z2D10-24GN

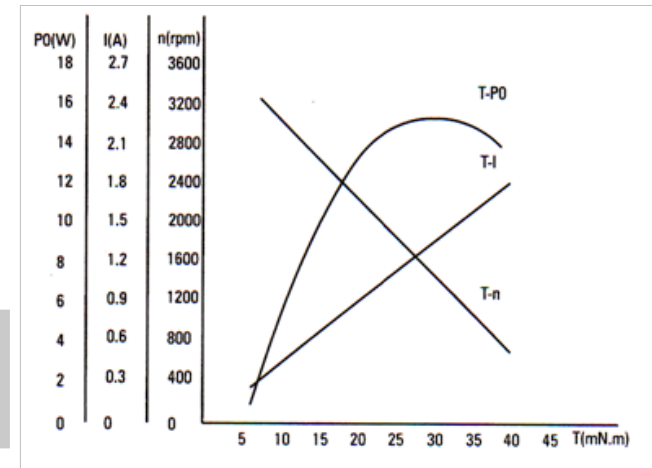
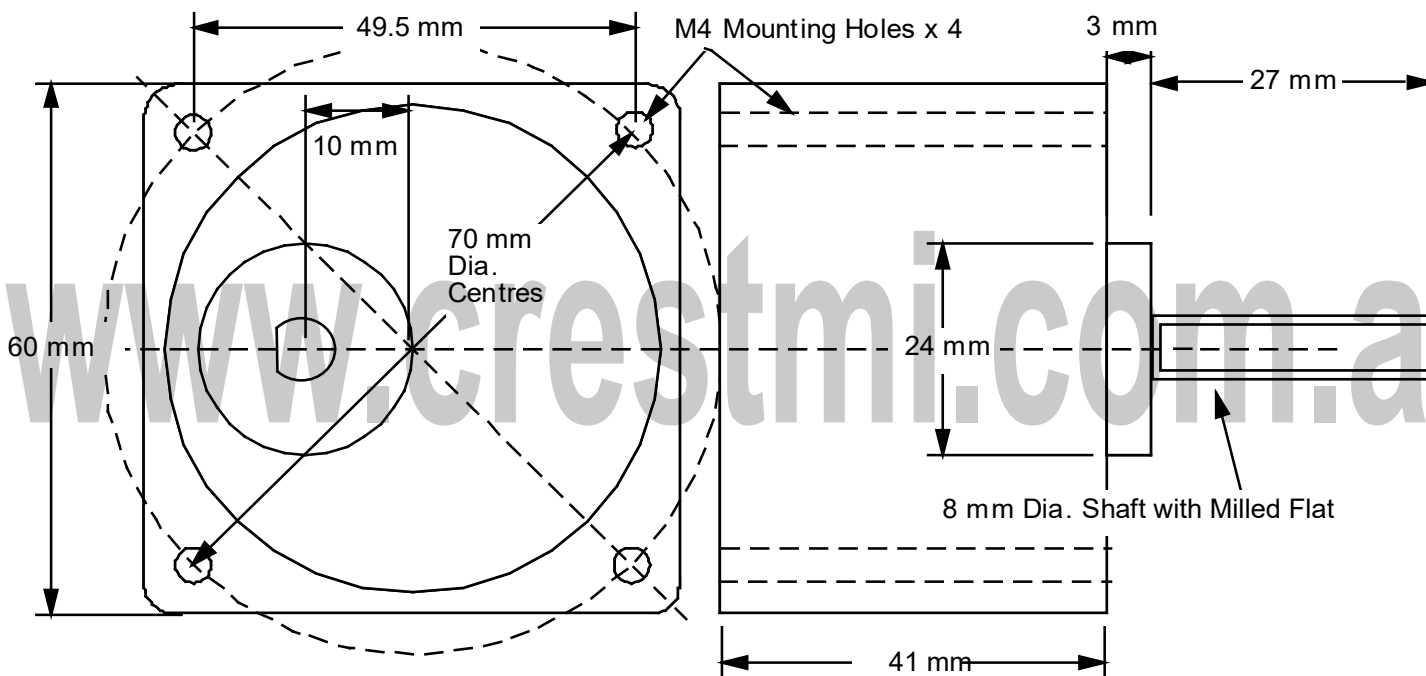

Precision 2GN Series Gearhead

