

**3000 RPM**

**12GN: 8 Amps Loaded  
2 Amps Unloaded**

**24GN: 3.8 Amps Loaded  
0.7 Amp Unloaded**

**Weight: 1.9 kg**

**ROTATION**

**Red to + Black to --: CW**

**Red to -- Black to +: CCW**

### Precision DC PM Motor - Z4D60-12GN & Z4D60-24GN

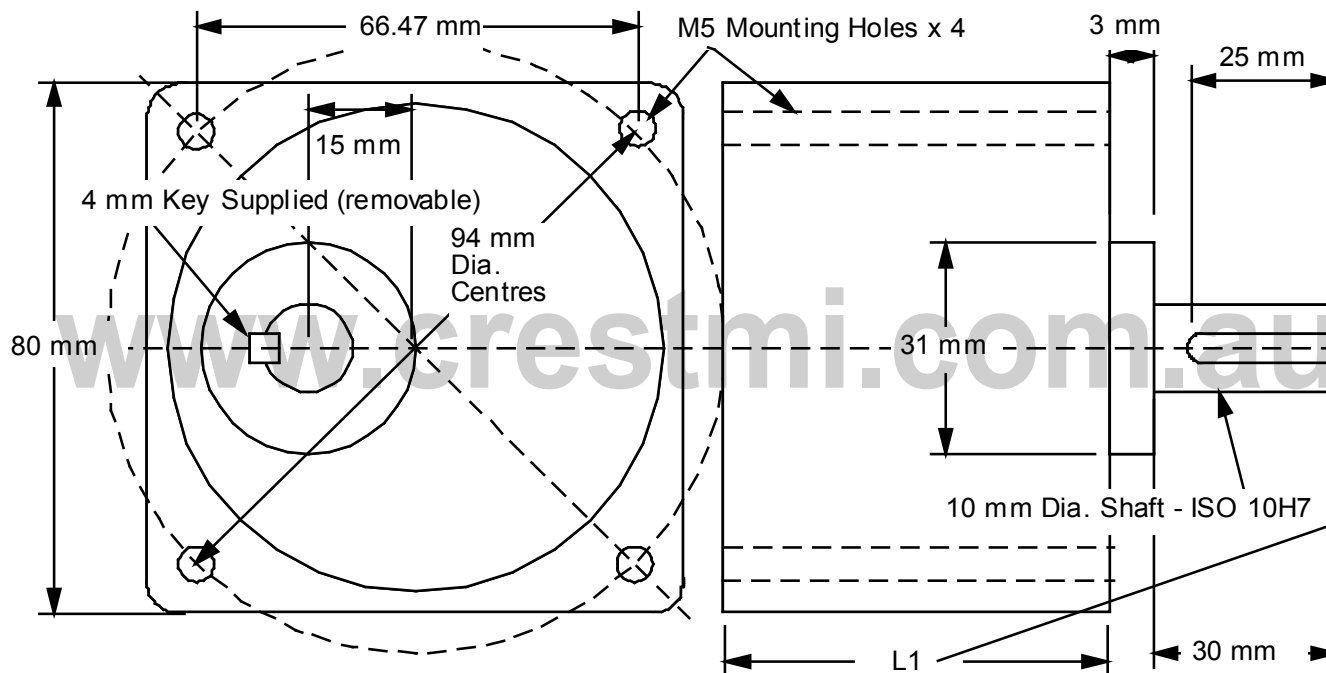

Note: For overall Gearmotor Length, add  
L1 to 120.5 mm (12GN) or 143 mm (24GN)  
Nominal Gearmotor Weight : ~ 2.75 kg

LI for 4GN 3K to 18K : **32 mm**  
LI for 4GN 25K to 200K : **42.5 mm**

### Precision 4GN Series Gearhead

